

Installation Instructions for Vista Air™ Vertically Folding Walls

Use these instructions in conjunction with your shop drawings to see the specifics that are particular to the model you are installing. Images below only represent the basic framework of the Vista Air™ Vertically Folding Wall (VA-100). Read these instructions completely before starting installation.

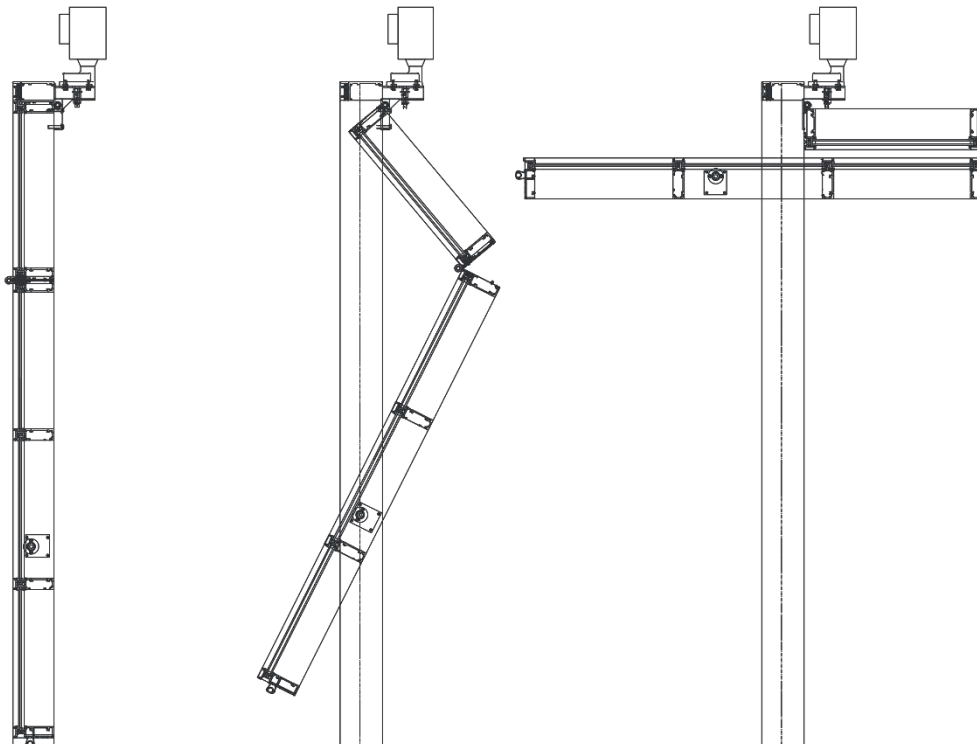
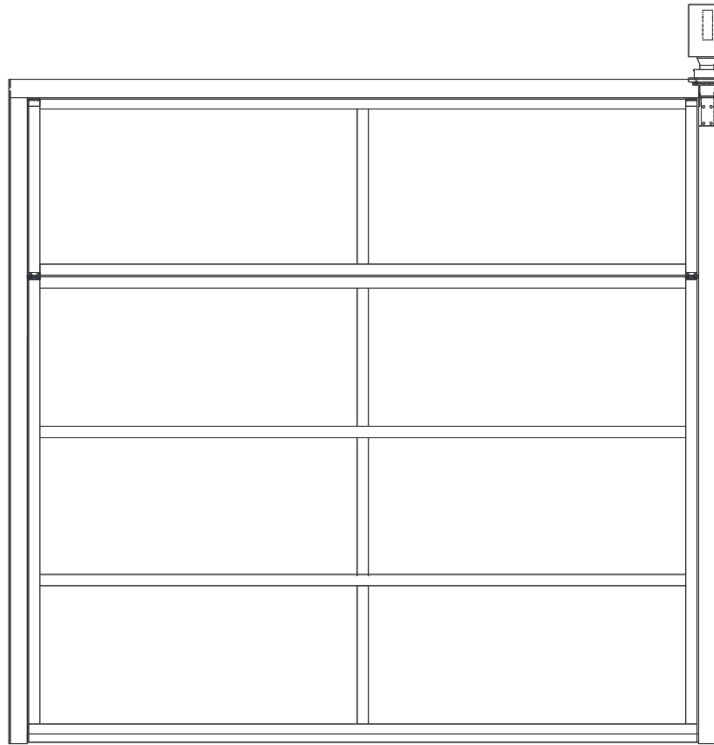

Table of Contents

Part 1: Preparation

1. Inspect material received
2. Clear work space
3. Tools required
4. Check rough opening

Part 2: Installation of Frame

1. Layout perimeter frames
2. Install perimeter frames
3. Verify trolleys are level
4. Install lead screw drive train

Part 3: Motor and Controls

1. Install drive mount
2. Install motor and main drive chain
3. Mount control box
4. Electrical wiring
5. Remove temporary locking pins

Part 4: Install Vista Air Wall Panel

1. Install upper panel
2. Install lifting wheel brackets
3. Install lower panel
4. Install lower cam wheels

Part 5: Install Glass

1. Prep window frames for glass
2. Install glass
3. Install motor housing
4. Install interior snap covers

See ***Electrical Instructions*** for motor, electrical and remote control set-up

Part 1: Preparation

- 1.1. Inspect packaging, uncrate carefully. Leave upper and lower panel sitting in crate (only take off top and sides of crate). Check components against packing list and parts list.
- 1.2. Clear workspace around wall opening. Let other workers in the area know that the opening will be inaccessible once installation has begun until it is complete. No hoses or cords should be run through the wall opening.

1.3. Required tools:

- Tape measure
- Drill/drill bits + extensions
- Screw gun (Phillips, flat head, sockets)
- 360 Laser Level
- Pliers (make sure you have needle nose)
- Center hole punch (under sized based on perimeter fasteners, only required for metal substrates)
- Protection for Vista Air product on the ground (use a mat, thick cardboard, padding, etc.)
- Lift straps (optional)
- Aluminum hard shims (ref: shim kit from factory)
- Chain tool (chain breaker)
- Allen keys
- Clamps and clamping devices
- Full set of open-ended wrenches (or socket wrench) 7/16", 3/8" & 9/16"
- Rubber mallet
- Hammer
- Scissors or razor blade (cutting glazing gaskets)
- Caulk gun
- Torque Wrench
- Dolly/wheel carts (optional)
- Dow Corning 985 sealant

Wiring and electrical tools and supplies:

- Small flat heads and Philip for wire terminals
- Wire strippers; wire crimpers; wire nuts; female disconnect terminals)
- 18 gauge wire (colors needed; blue, yellow, black, green, white, brown and red) enough length to run from bottom of door to the control box location
- 12 gauge wire (colors needed; red, white, orange, black/white) enough length to run from motor to control box

1.4.

- a. Check your rough opening for squareness and dimensions. Ensure that the finished floor height matches the shop drawings.
- b. Check that there is clearance for the VA-100 frame assembly.
- c. Check that the mounting substrates are the same material as those on the shop drawings.

- d. Using the laser, mark vertical reference lines on rough opening sides for use in positioning the front plane of the fixed jambs and the fixed head in the vertical plane.
- e. Using the laser, mark horizontal reference lines on rough opening sides for use in positioning the fixed jambs at equal heights.

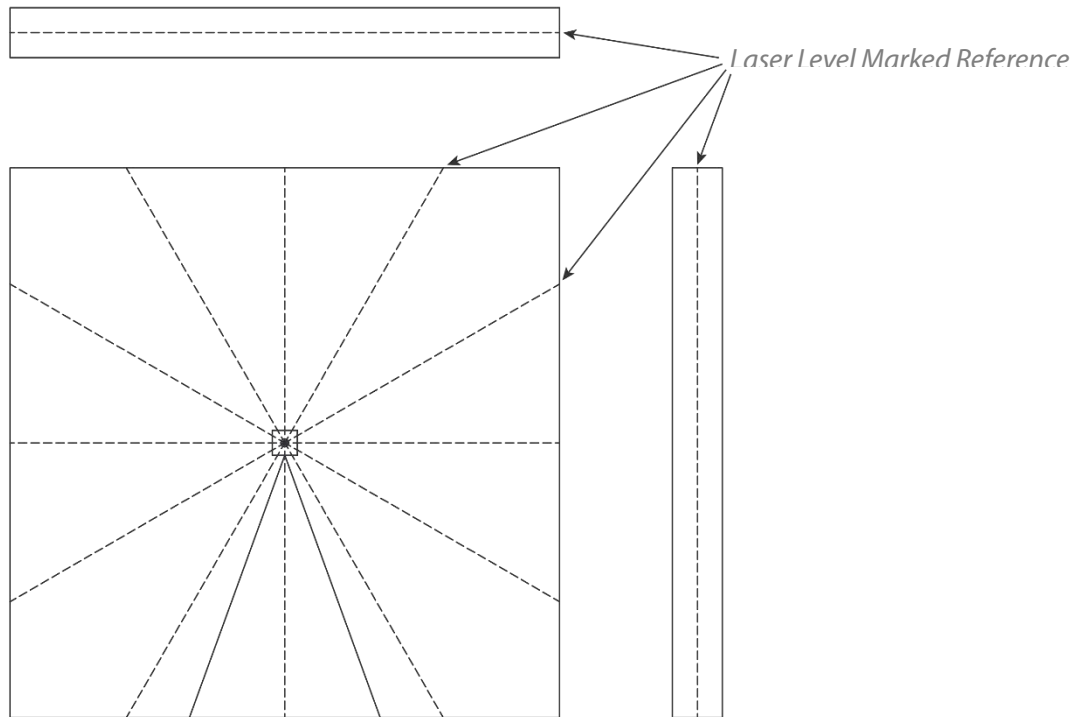

Part 2: Assembly - Installation of Frame and Upper Wall Panel

2.1. Lay out perimeter frames (Vista Air to identify: VA-100 jamb, VA-100 head, etc.)

NOTE: Trolleys have been factory positioned and locked in the fixed jambs. **DO NOT MOVE TROLLEYS.**

2.2.

- a. Check pre-drilled anchor holes into the VA-100 frames for fastener locations against the shop drawings. Fasteners shall be as called out on shop drawings. Use supplied templates to drill into perimeter.
- b. Using the reference marks on the rough opening sides, install the fixed jambs. Ensure that the opening of the jambs are on the inside of the opening (refer to shop drawings). Use factory painted shims (from shim kit) to ensure both jambs are at a level height. Shim between the fixed jambs and building as required. Ensure that distance from inside faces of both jambs match jamb day light opening on shop drawings. Check this dimension at 12" increments for entire height of Vista Air jambs. **Note:** Shims must be positioned so that the fixed jambs are fully supported across their depth with no rocking.

- c. Make sure that the anchor heads do not project into the jamb more than $5/8"$ to prevent any interference with trolley travel. See sketch below.

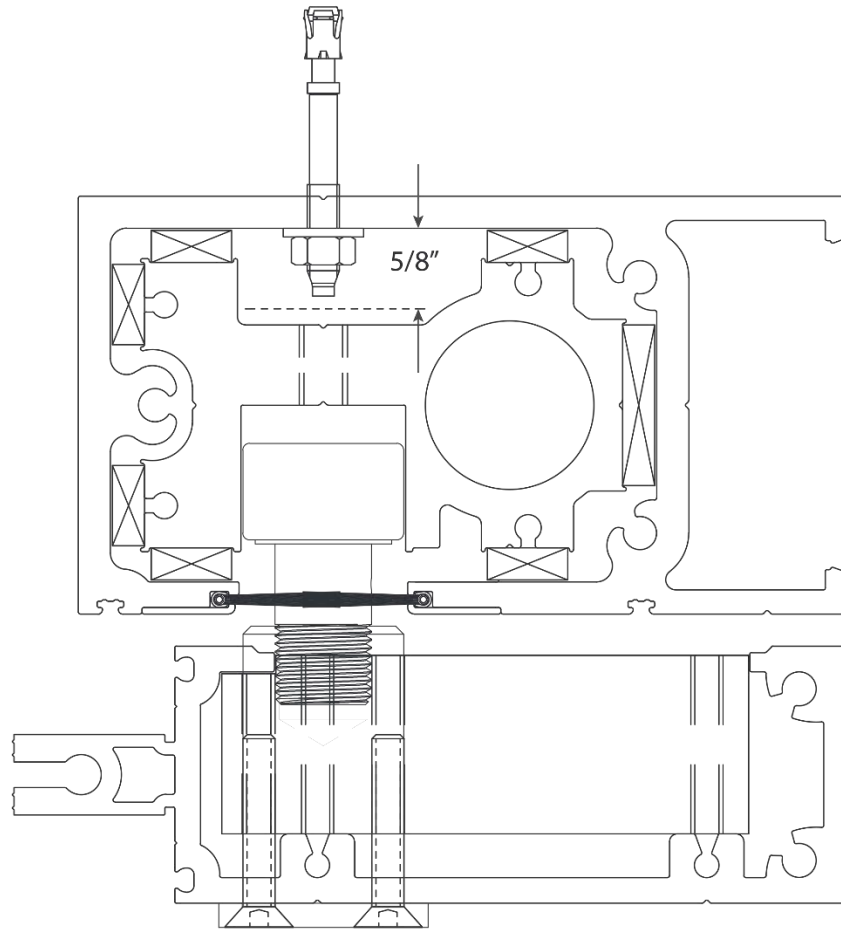

- d. Using the reference marks on the rough opening top, install fixed head. Hard shim as necessary to ensure fixed head is level in opening. The exterior face of the fixed jambs must be in the same plane as the exterior face of the fixed head. Install bolts that secure head and jambs together with head/jamb angle (angle is factory-attached to jambs).
- e. Check the fixed frame squareness using diagonal measurements. The difference between the diagonal measurements should not exceed $1/4"$

- 2.3.** Using the top of the trolley for reference and using the laser level, make sure both trolleys are at the same height. If they are not, remove the lead screw lock O-ring and lead screw lock located at the top of the lead screw. Rotate the lead screw until the top of the trolleys are at the same height.
- 2.4.** Remove the lead screw lock O-ring and lock from the other lead screw. The locks are no longer needed.
- 2.5.** Inside the fixed head and jambs, fit lead screw drive chain around sprockets and connect with included chain link. This chain must be installed on the lower sprocket of the drive side. Remove any links required to remove any slack in the chain.

Part 3: Motor and Controls

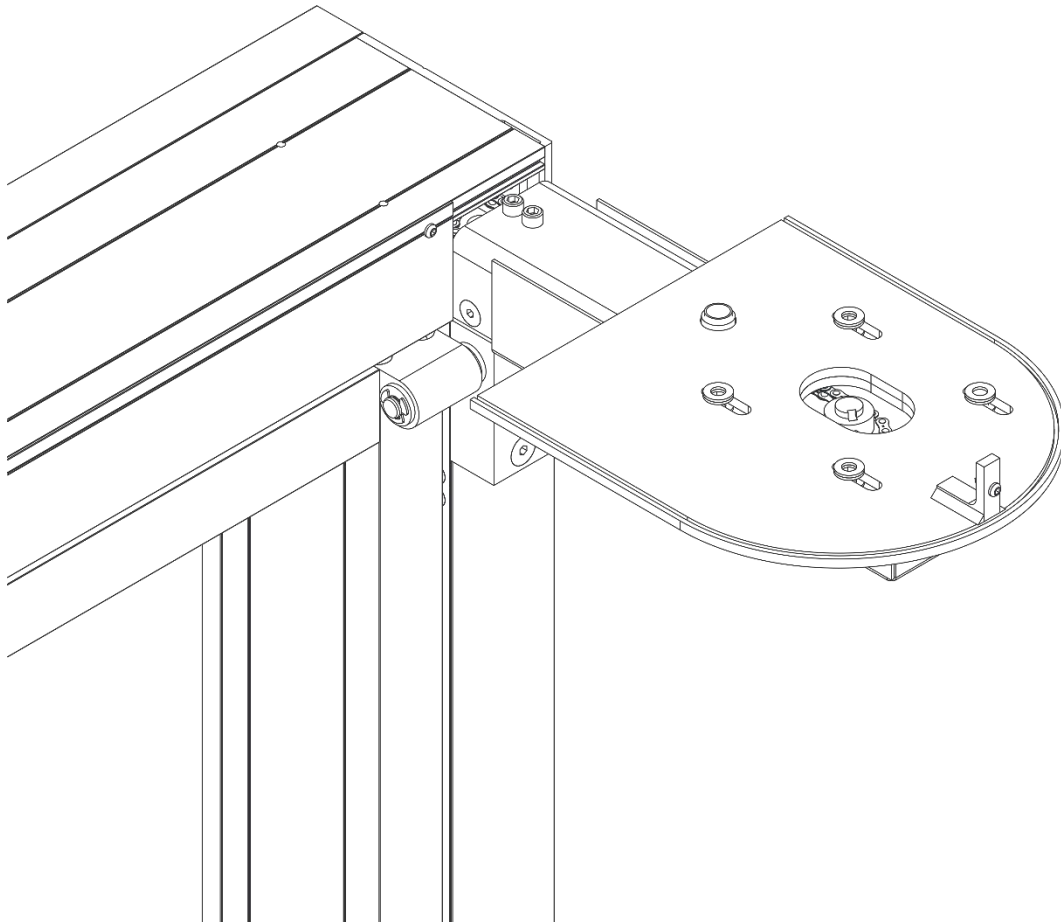

- 3.1.** Install motor to drive mount, then fit main drive chain around sprockets. Adjust the drive mount to take up any slack in the chain.
- 3.2.** Mount the control box in the chosen location (wires must not be more than 100 feet long from motor to control box).
- 3.3.** Wire the control box, motor power, and control switch for temporary operation per the Electrical Installation Instructions. Connect the control box to temporary power provided by the GC.
- 3.4.** Operate Vista Air motor to make sure trolley travels full height and back. Return position of the trolley to lowest height. The limit switches at top and bottom should be shop adjusted, so the trollies will not over travel.

Part 4: Install Vista Air Wall Upper Panel

- 4.1. Position upper panel inside of Vista Air jambs. Using temporary lift pins, insert pins into holes on each side of upper panel so that the pin rests on cam wheel support block (See shop drawings for this reference). Operate Vista Air VA-100 to raise upper panel into position. With hinges aligned, install hinge pins from the interior, outward. Remove temporary lift pins and install factory painted plugs. Operate Vista Air VA-100 to lower trolley to bottom position.

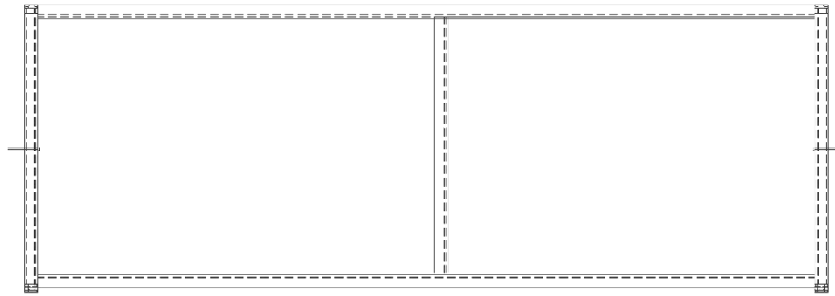

Upper Panel

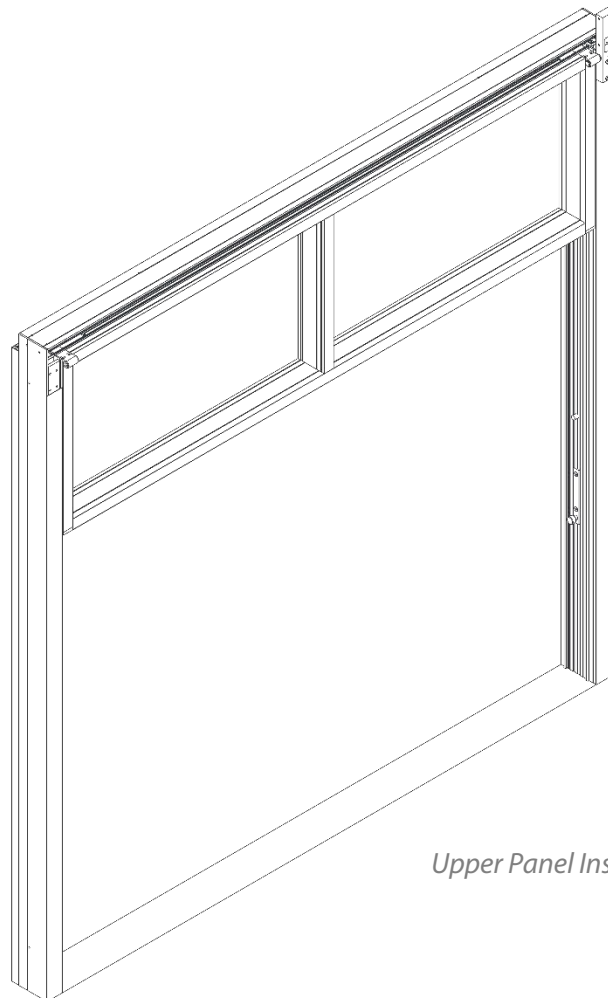

Upper Panel Installed Position

- 4.2.** With trolley at its lowest height, position lower panel in perimeter opening and install the lift wheel brackets as shown below on both sides of lower panel. Lifts may need to raise the panel to get it into position so the lift wheels sit in the correct position on the trollies. This may require tilting the lower panel at an angle to make sure lift wheel sits inside of trolley and not on top of trolley.

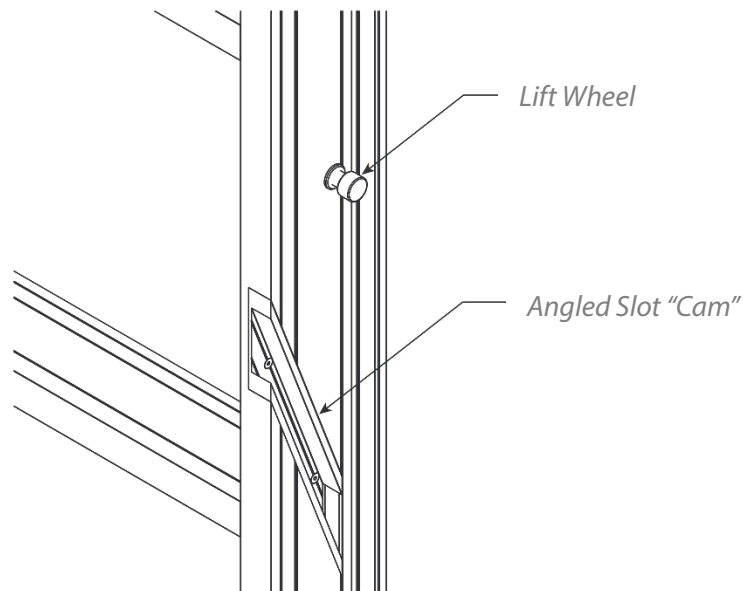
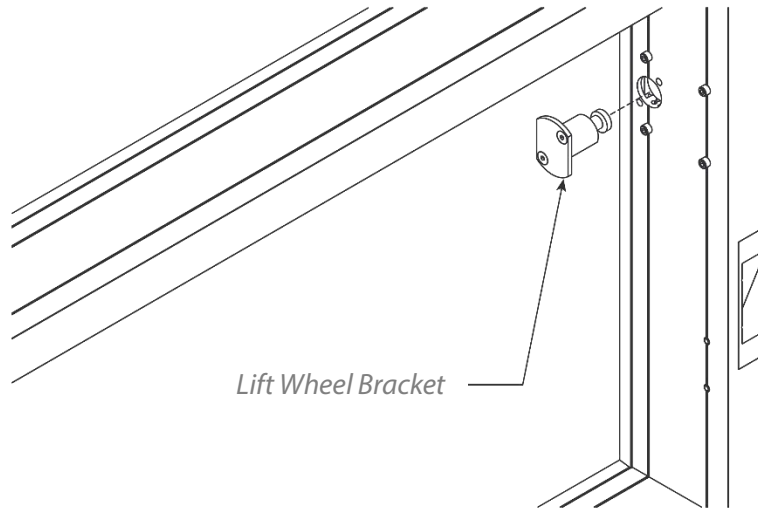

- 4.3.** Slope the lower panel so that the top of the panel is on the interior side. Operate the motor until you can rotate the upper and lower panels together so the pins connecting the hinges (upper and lower panel) can be installed. Hinge Pins should be installed from the exterior inward for the jamb hinges. Intermediate hinge pins can be installed from either side. Install snap rings onto hinge pins and tighten the 6-32 setscrew on the hinges that have them.

- 4.4. After slipping on cam wheel bearing spacer onto separate cam wheels, apply supplied blue Loctite onto each lower cam wheel threads. With the lower panel still sloped, install the lower cam wheels into each trolley.

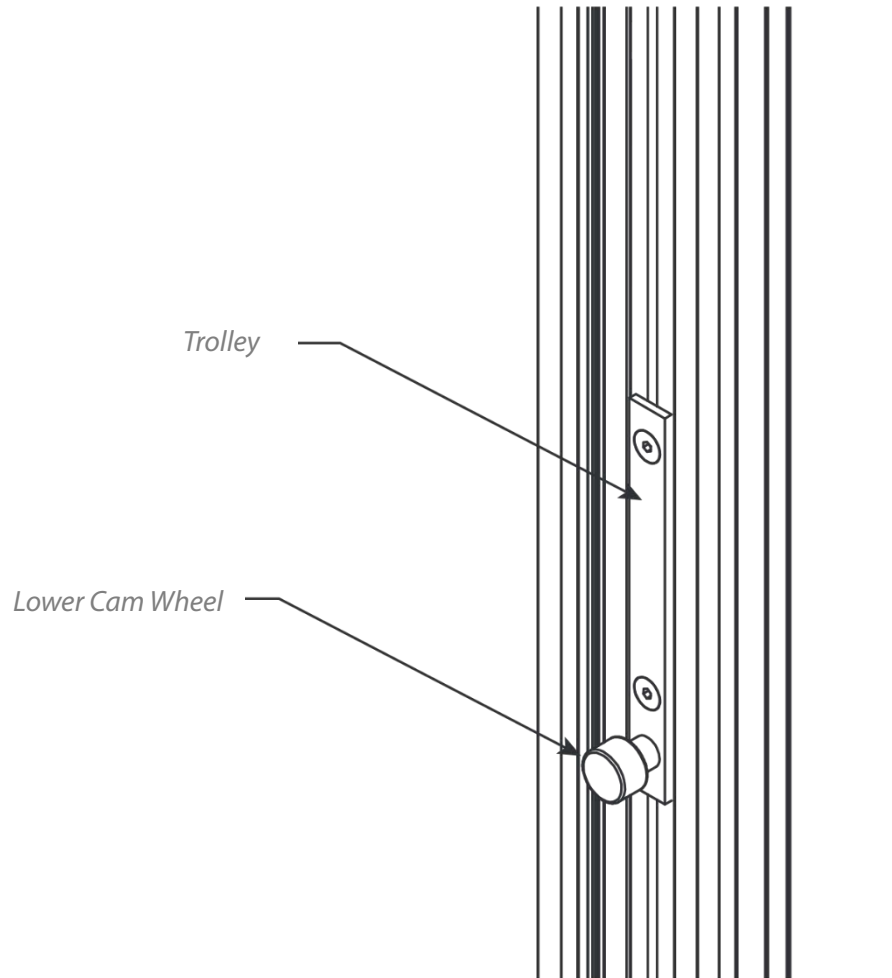

Part 5: Install Glass

- 5.1. Prepare frames for glass; Lay out pressure plates, snap covers, gaskets and setting blocks.
- Inside glass gaskets are shop attached as well as pressure plate gaskets
- 5.2. Using Dow Corning 985, seal inside of glazing pocket everywhere the vertical member meet the horizontal members.

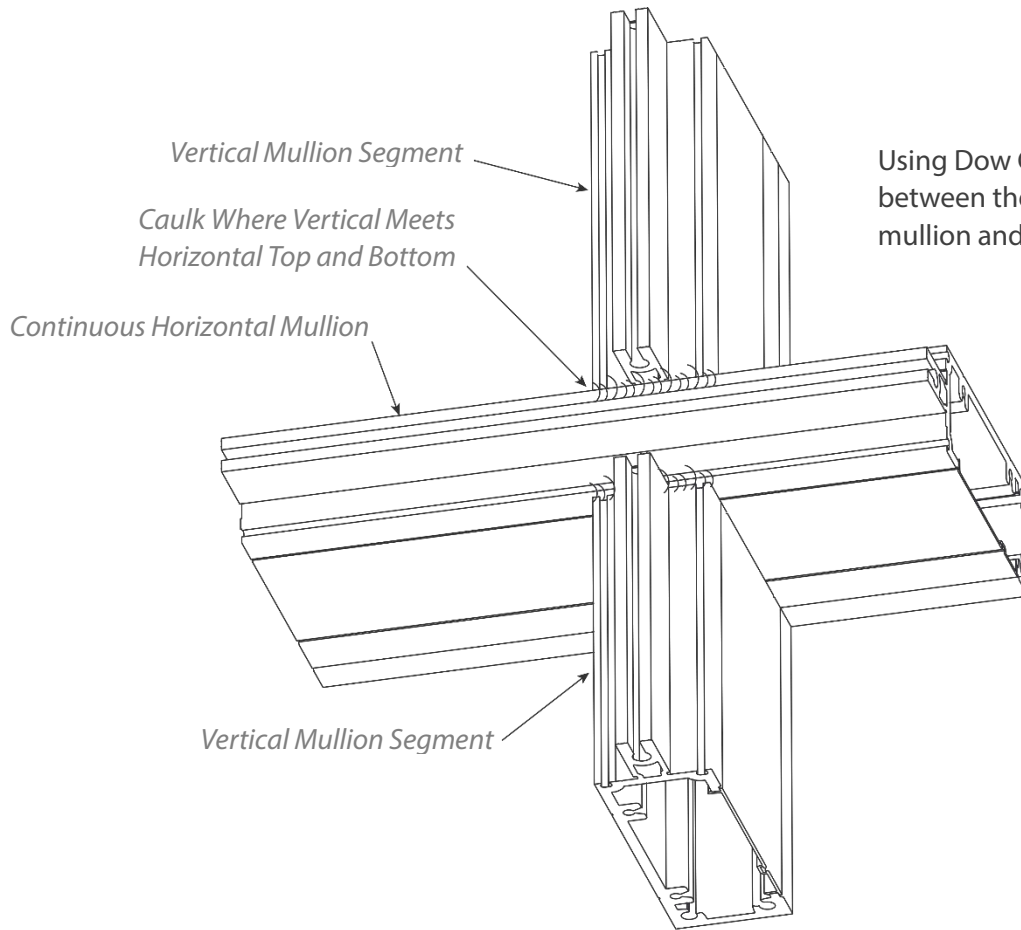

Using Dow Corning 985, seal the junction between the horizontal intermediate mullion and the vertical mullion segment.

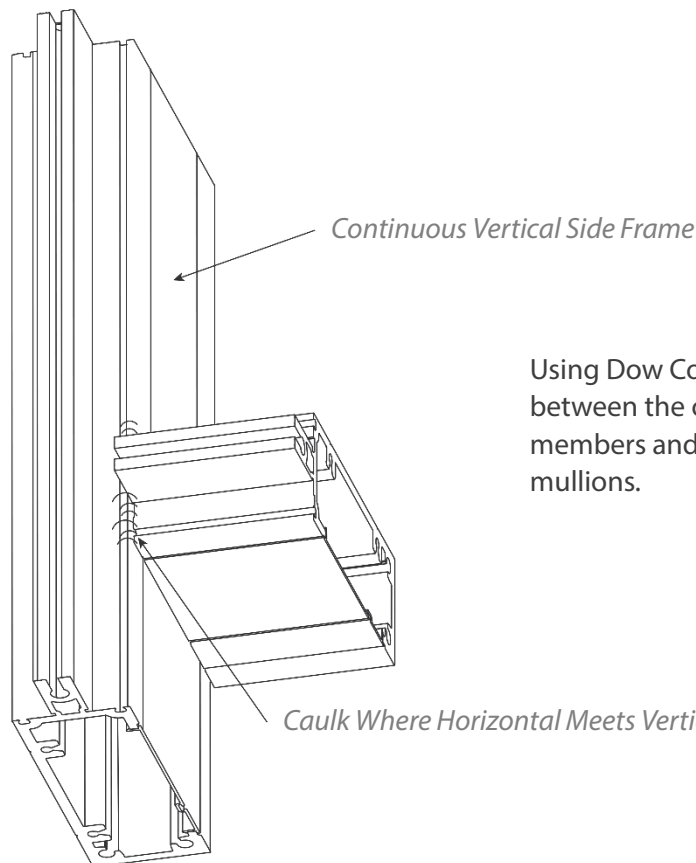

Using Dow Corning 985, seal the junction between the continuous vertical outer frame members and the horizontal intermediate mullions.

5.3. Install setting blocks in bottom of glazing pocket – one block in each corner for a total of 2 per pane.

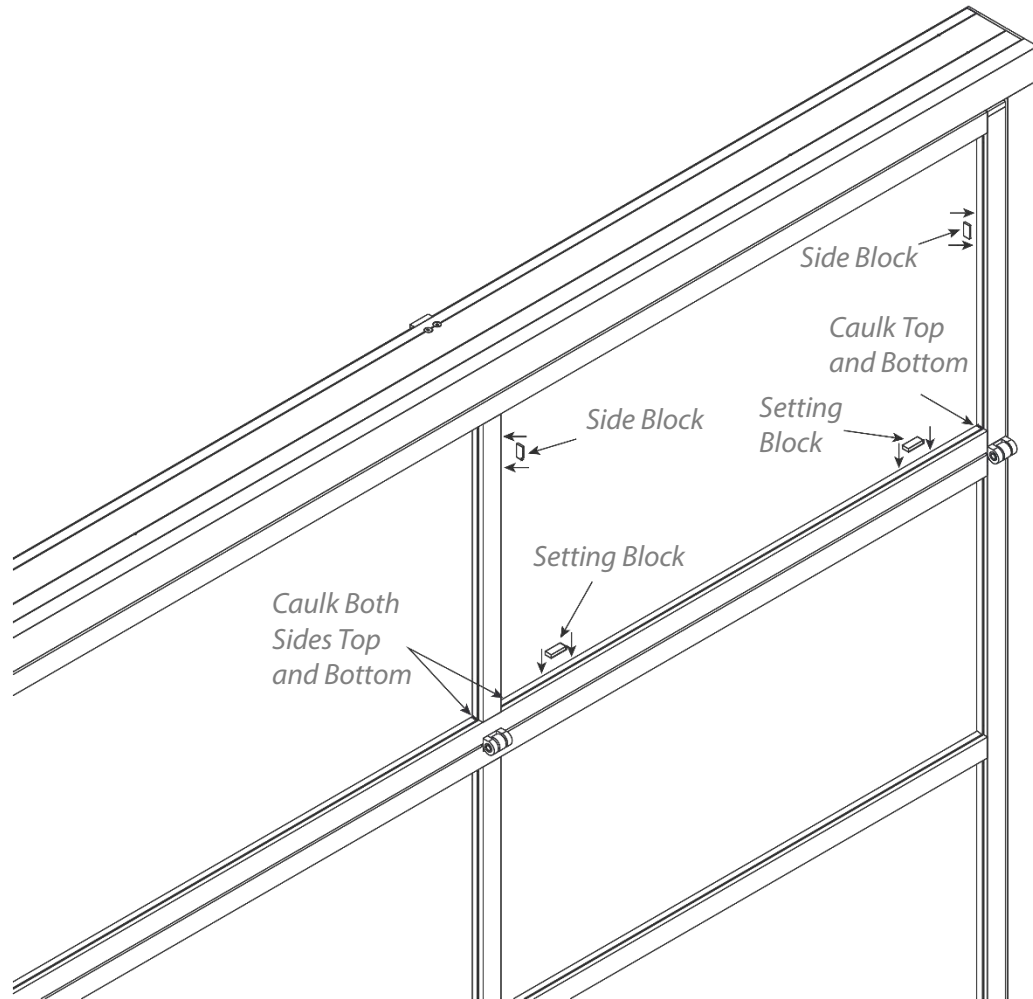

5.4. Drop in glass panes in the appropriate opening.

5.5. Insert side blocks between glass panes and aluminum frame $\frac{1}{4}$ of the way down from the top of the glass. Only one side block is required per side.

5.6. Trim outside gaskets on the pressure plates if necessary.

5.7. Install pressure plates.

b. Install pressure plates using screws $\frac{1}{4}$ -14 x 1" LG hex washer head type AB.

c. Screws are to be located 4" OC. Always locate a screw as close as possible to a horizontal joint. This will provide maximum pressure for the critical joint seals.

d. Install horizontal pressure plates with weep holes towards the top of the horizontal.

e. At each horizontal and vertical pressure plate, install two screws part way, then install the 3rd screw all the way. After that, tighten the first two screws. This eliminates lateral walking of the pressure plate position.

f. Torque all screws to 95-100 inch-lbs. during cold weather. Torque screws to 50 in-lbs. until all 4 sides have been clamped, then torque screws to 95-100 in-lbs.

- 5.8. Install snap caps on pressure plates. Make sure the covers are fully snapped the entire length of the caps.
- 5.9. Install motor housing.
- 5.10. Install Interior jamb snap covers and head cap.

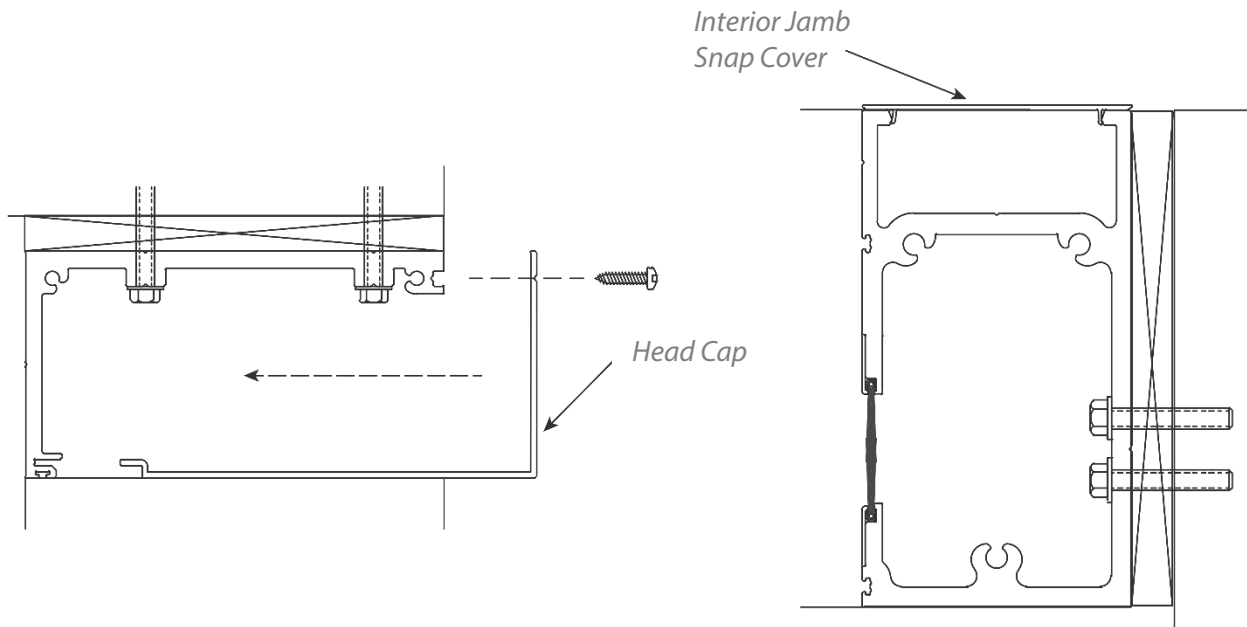

Part 6: Adjust Sill Gasket Carrier

- 6.1. Make sure the door is completely closed, then measure the height of the sill gasket carrier to the floor right, left and center.
- 6.2. Loosen the screws on the inside face of the sill gasket carrier and move up or down to have an average gap of 1 15/16". Retighten the screws and measure again.
- 6.3. Check to make sure the lower panel sill gasket is slightly compressed, sealing the gap at the floor.

Part 7: Adjust of Optional Photo Eye

- 7.1. Open the door and check the adjustment of the optional photo eye. It should be pointed directly at the reflective tape on the opposite fixed jamb. An indicator light on the photo eye will be illuminated if the photo eye is properly aligned with the reflective tape.
- 7.2. Block the photo eye, and the door should not operate.